

TRU35 Wireless Data Transceiver

User Manual_V1.2



Contents

1. Introduction	3
2. Key features	4
3. Technical Specifications	5
4. Product Interface	6
4.1 LED Display	6
4.2 Buttons	7
4.3 Channel Display	7
5. Connection Port	8
5.1 Definition of 5-Pin	8
6. Configuration	9
6.1 Connect TRU35.....	9
6.2 Parameter Setting.....	10
6.3 Channel Detect.....	10
6.4 Equipment Information.....	11
6.5 Temperature Control	11
6.6 Radio Control.....	12
6.7 Firmware Update.....	12
7. Working Mode	12
7.1 Serial Mode	12
7.2 Bluetooth Mode	12

1. Introduction

TRU35 is a high-power, small-size, half-duplex digital radio model which is designed using advanced 32-bit cortex M4 microcontroller technology, wireless transceiver RF technology, and digital communication technology. It uses high-quality RF components, excellent EMC and EMI processing. The utility model has the advantages:

- **High transmission power**
- **Long transmission distance**
- **Integrated transmission and reception**
- **Convenient installation**
- **Easy to use**
- **Stable and reliable**



Figure 1.1

2. Key features

- **All in one**

Integrated with transmitting and receiving functions.

- **Radio Relay**

Increase the transmitting distance by receiving data and transmitting out using different frequency.

- **Power Protection**

Two-stage surge protection is used to protect the radio from damage when the input voltage or current exceeds the normal range or positive and negative stages are reversed.

- **Standing Wave Detection Protection**

Prevent damage caused by long-time open circuit or short circuit.

- **Good Heat Dissipation**

One-piece molded case makes it easy to perform good heat dissipation.

- **Thermal Protection**

TRU35 can adjust the transmit power adaptively, automatically reduce the power when temperature is too high, and increase the power when temperature decreases. Ensure radio equipment is always in a stable power range and will not be damaged by overheating.

- **IP67 Protection**

- **Bluetooth Function**

Bluetooth can be used to configurate operating mode, protocol, frequency, power level as well as receiving data and transmitting out using radio.

- **16 Channels**

User can switch frequency quickly with 16 radio channels.

- **Long Transmission Distance**

Transmission distance can reach 14Km with high power level (Optimal conditions)

3. Technical Specifications

General Specifications		
Frequency Range	410~470MHz	
Operating Mode	Half-duplex	
Channel Spacing	12.5KHz/ 25KHz	
Channels	16	
Modulation	GMSK/ 4FSK	
Operating Voltage	Nominal voltage 12.5V (10.8~15V)	
Power Consumption (Typical)	Transmit (High Power)	91W
	Receive	6.5W
RF Power Stability	≤±1.0ppm	
Dimension	165×125×81mm	
Weight	1680g	
Operating Temperature	-40~+85°C	
Storage Temperature	-45~+90°C	
IP Rate	IP67	
Antenna Interface	TNC, female	
Antenna Interface Impedance	50ohm	
Data Interface	LEMO 5pin	
Transmitter Specifications		
RF Output Power	10W/ 30W (12.5V Input)	
RF Power Stability	±1.5dB	
Adjacent Channel Inhibition	>50dB	
Receiver Specifications		
Sensitivity	Better than -116dBm@BER 10 ⁻⁵ , 9600bps	
Co-channel Inhibition	>-12dB	
Block	>70dB	
Adjacent Channel Selectivity	>52dB@25KHz	
Perturbation Resistance Stray	>55dB	
Modulator		
Air Rate	9600bps, 19200bps	
Modulation	GMSK/ 4FSK	



4. Product Interface





Figure 4.1

4.1 LED Display



There are 5 LED indicators showing current working status.

Indicator	Color	Description	
Voltage 	Green	Solid green	Power on
		Flash 1Hz	Low voltage (flash when lower than 11.3V, stop transmitting when lower than 10.5V)
		Flash	Stop working when temperature is higher than 90°C
High Power 	Green	On	Transmitting with high power (30w)
		Off	Transmitting with low power (5W)
Transmitting 	Green	Off	Default
		Flash	With transmitting data frequency

Receiving 	Green	Off	Default
		Flash	With receiving data frequency
Bluetooth 	Blue	Solid blue	With connection
		Flash	Transmitting data
		Off	No connection

4.2 Buttons

User can switch power, channel number and power on/off device with buttons.

Buttons	Function
Switch low/high power 	Switch transmitting power to low/high level
Power on/off 	Power on/off
Switch channel 	Switch channel (Can only switch TX channel. Need to use software to switch RX channel)

4.3 Channel Display

The panel show current transmitting channel.

Display	Function
	Show current channel number: 1~9~0: Channel 1~10 a~f: Channel 11~16

5. Connection Port

There are two ports on TRU35 for external antenna and power/serial.



Figure 5.1 Radio Antenna Port



Figure 5.2 Power/Serial Port

Port	Function
Radio antenna	TNC, connect to external radio antenna
Power/Serial	Provide power and connect to 5pin/DB9 serial port

5.1 Definition of 5-Pin

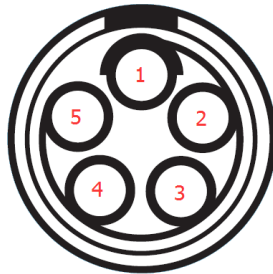

Figure 5.3

5-pin Definition	
Pin No.	Definition
1	VCC, 5.5-16V
2	GND
3	RXD
4	GND
5	TXD

Serial port baud rate setting	9600~25600
Data bits	8
Stop bit	1
Check bit	None

6. Configuration

The configuration software has been integrated into SurPad4.0 data collection software.

6.1 Connect TRU35

- Start SurPad4.0 software, then find Tools -> External Radio Configuration

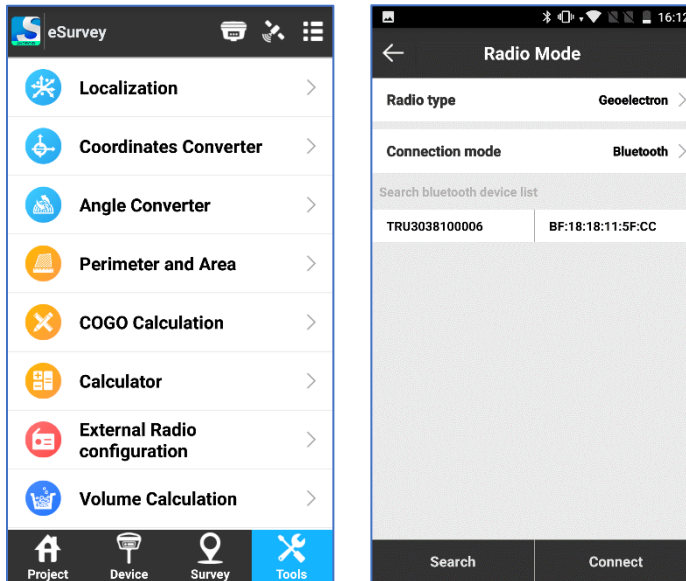

- “Radio type” choose “Geoelectron”, “Connection mode” choose “Bluetooth”
- Then click “Search” to search device. You will see radio serial number in the list
- Select the device and click [Connect], the Bluetooth indicator will turn blue
- Click “Settings” to show setting page

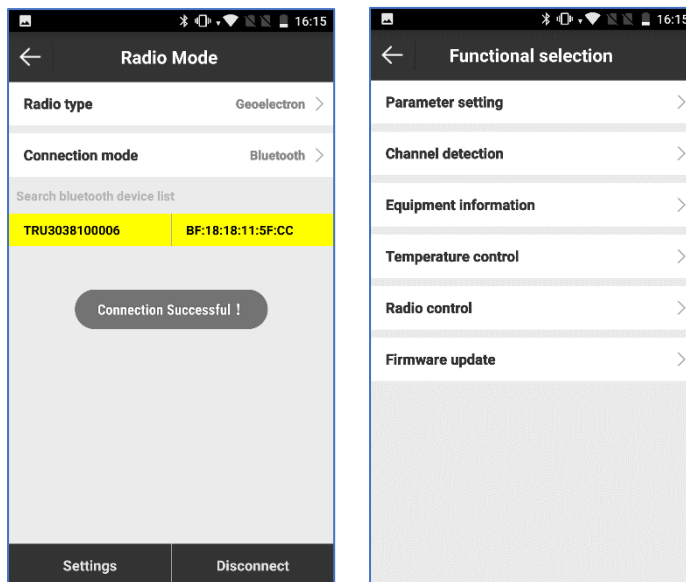

Note:

1. Disconnect GPS receiver before you connect external radio
2. The first time to connect, it will ask to input pair code: 1234

6.2 Parameter Setting

In this page, you can set channels frequency, radio protocol, baud rate, relay function and alert for low power level/high temperature.

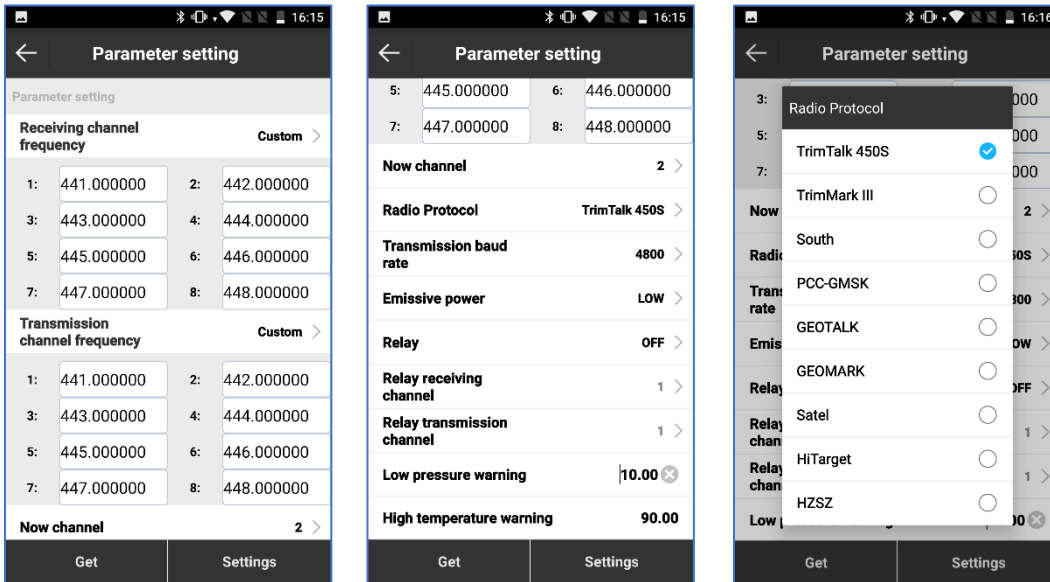

Note:

1. The frequency must be supported by external radio antenna.
2. When relay function is enabled, receiving channel should be same with Base, transmitting channel should be same with Rover.
3. When relay function is enabled, the radio protocol should be the same.
4. When relay function is enabled, receiving and transmitting frequency can't be the same.
5. Low pressure alert is set to 10.5v by default. When lower than 11.3v, the power indicator will flash but still can transmit data. When lower than 10.5v, the power indicator keep flash and stop transmitting data.
6. High temperature warning is set to 90°C by default. The power indicator will flash and stop transmitting data when higher than 90°C.

6.3 Channel Detect

In this page, you can detect the strength of predefined/customized frequency.

Note:

1. The external radio antenna is required for this function.
2. If the detected frequency strength is strong, that means some other people may be using this frequency.

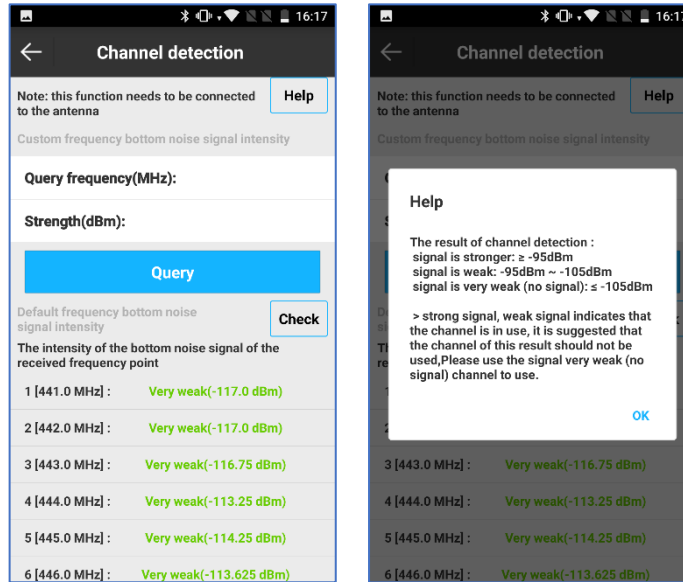

6.4 Equipment Information

In this page, you can view device information like current temperature and power level.

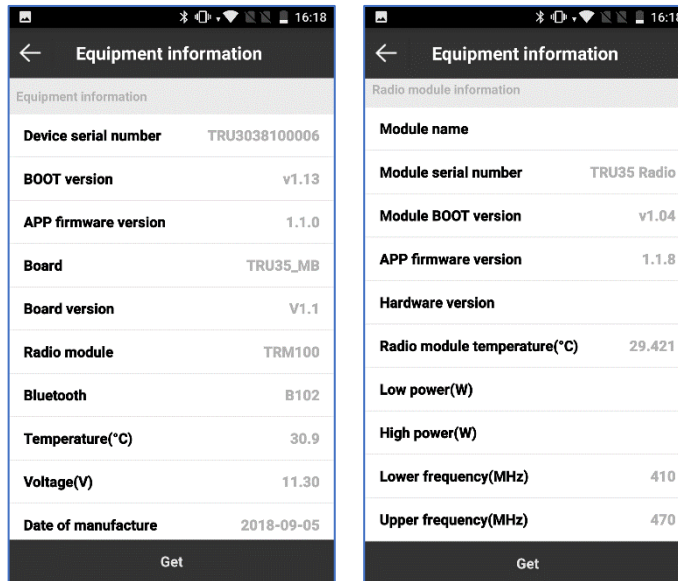

6.5 Temperature Control

In this page, you can set temperature threshold and power gain. For example, in below picture the first level threshold is set to 60°C, second level threshold is set to 85°C. When the temperature achieves the threshold, it will reduce the transmitting power automatically. The level to reduce power is depending on the gain value. The absolute value of gain is higher, the more power level will be reduced.

Note:

1. Temperature range: -100~1000 °C
2. Gain range: -60~60 °C

- The first level temperature must be lower than second level.

6.6 Radio Control

In this page, you can set radio baud rate, restart or power off device and restore factory setting.

6.7 Firmware Update

In this page, you can update radio firmware. In the process of updating, the power indicator will flash with 5Hz frequency. After finished, device will restart automatically.

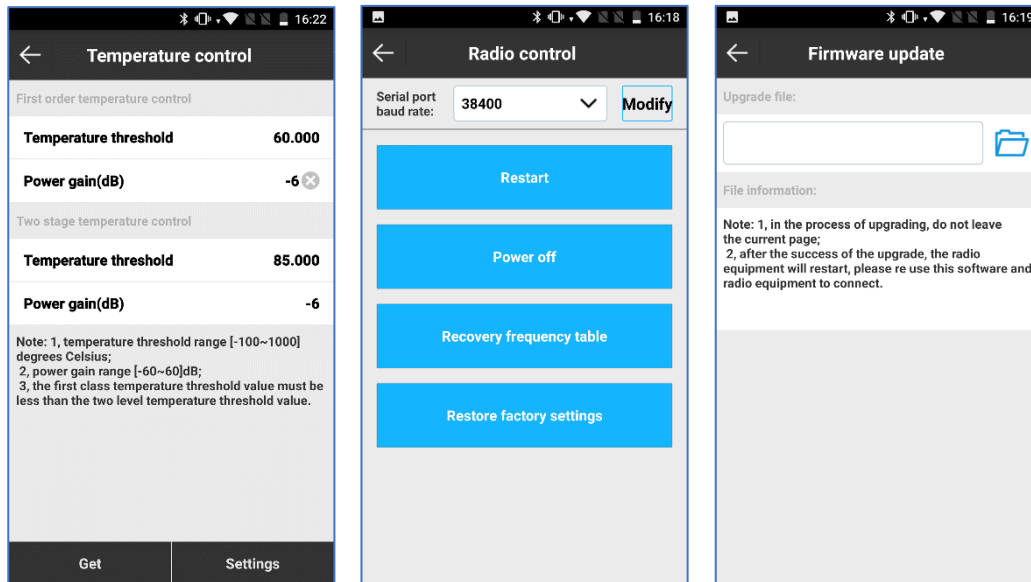

7. Working Mode

TRU35 have two kinds of working mode: Working with base station and been used as external radio to transmit correction data; or used as relayed radio to receive correction data, then transmit the data with another frequency.

7.1 Serial Mode

To connect GPS receiver with serial cable, then set receiver as external radio mode. After finished, The TX indicator will flash.

Note:

- The baud rate should be same with TRU35 when configurate GPS receiver
- The default baud rate is 38400

7.2 Bluetooth Mode

TRU35 support to transmit data without serial cable. Firstly, log into GPS receiver WebUI. Then set working mode as Bluetooth, search the radio serial number and save the setting.

After finished, the Bluetooth indicator and TX indicator will flash which means the radio is receiving data through Bluetooth and transmit out with radio frequency.

*To be the leading provider of high-precision professional,
solution & service in the global geospatial industry*

Shanghai eSurvey GNSS Co., Ltd.

Address: Building 4, No.651 Wanfang Rd, Pujiang Town, Minhang District, Shanghai, China

E-mail: Sales: info@esurvey-gnss.com Support: support@esurvey-gnss.com

Hotline: +86 400-999-8088

Website: <https://esurvey-gnss.com/>

